

Data acquisition system ALMEMO® 5690-1M

V2.2
04/04/2022

1. OPERATING CONTROLS

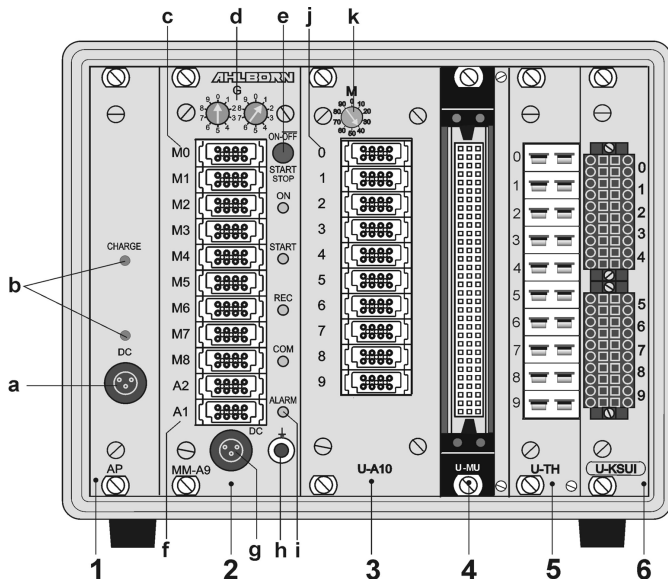

(1) Module AP: rechargeable battery (option):

(a) Connection socket DC-A 12V
Mains adapter (ZB 1212-NAx, 12V, 2.5A)

(b) Check lamps
DC-A Mains supply present
CHARGE Batteries are being charged

(2) Module MM-A9:
Measuring circuit board AL-MEMO®

(c) Measuring inputs M0 to M8
M0 to M8 for all ALMEMO® sensors
M9 to M39 31 additional channels

(d) Code switches
G: device address 0 to 99

(e) Key ON/OFF, START/STOP
ON ON
START Start measuring operation
STOP Stop measuring operation
OFF OFF, Hold key pressed
down

(f) Output sockets A1, A2
A1 Interface / optic fiber (ZA1909-DK5/L)
RS 422 (ZA 5099-NVL/NVB)
Ethernet (ZA 1945-DK)
Radio (ZA 1709-BTx)
A2 Network cable (ZA1999-NK5/NKL)
MMC-card connector (ZA1904-MMC)
A1/A2 Trigger input (ZA 1000-ET/EK)
Relay outputs (ZA 1000-EGK)
Analog output 2 (ZA 1601-RK)

(g) Connection socket DC 12V
Mains adapter (ZB 1212-NA6, 12V, 5A)
Cable, electrically isolated (ZB 3090-UK2, 10-30V)

(h)
(i) Check lamps
ON Device switched ON
START Measuring operation started
REC Measuring with results saved
COM Measuring with output
ALARM Limit value exceeded
Sensor breakage, LoBat

Extension of measuring points with selector switch boards:

(3) Module U-A10: selector switch board for 10 ALMEMO® sockets

- (j) **Code switch M:** measuring point x: 10 to 90
- (k) **Measuring inputs 0 to 9** x0 to x9 for 10 ALMEMO® sensors
x+10 to x+39 max. 30 additional channels

(4) Module U-MU: selector switch board 10x MU connector

- Code switch internal:** measuring point x: 10 to 90 on board
- Measuring inputs** x0 to x9 for 10 sensors without power supply
x+10 to x+39 maximum 30 additional channels

(5) Module U-TH: selector switch board 10 thermal sockets

- Code switch internal:** measuring point x: 10 to 90 on board
- Measuring inputs** x0 to x9 for 10 sensors with miniature thermal connectors
x+10 to x+39 maximum 30 additional channels

(6) Module U-KS: selector switch board for 2 clamp connectors

- Code switch internal:** measuring point x: 10 to 90 on board
- Measuring inputs** x0 to x9 for 10 sensors without power supply
x+10 to x+39 maximum 30 additional channels

(7) Module RTA5: Relais-Trigger-Analog-Module

for 5 orange ALMEMO® clamp connectors

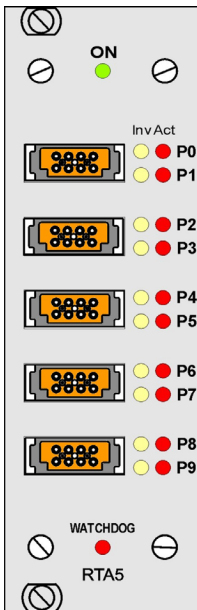

Sockets P0/1 bis P8/9

- R0, R1 P0/1 2 semiconductor relays
- R2, R3 P2/3 2 semiconductor relays
- P4/5 2 analogue outputs (Option)
- P6/7 2 analogue outputs (Option)
- P8/9 2 trigger inputs TR8, TR9

LED-Signallampen

- ON** Power supply switched ON
- Px Act** Port active
- Px Inv** Port driven inverted
- WATCHDOG** Drive failure

2. CONTENTS

1. Operating controls	2
2. Contents	4
3. General	6
3.1 Warranty.....	6
3.2 Scope of delivery	7
3.3 How to deal with rechargeable batteries (option)	7
3.4 Special notes on use	7
4. Introduction	8
4.1 Functions of the ALMEMO® 5690-1M.....	8
4.1.1 Sensor programming	9
4.1.2 Measuring operations	10
4.1.3 Process control	11
5. Initial commissioning	13
6. Power supply	14
6.1 Mains operation	14
6.2 External DC voltage supply	14
6.3 Operation with rechargeable battery (only with module ES5690-AP) 14	
6.4 Sensor supply	15
6.5 Switching ON / OFF,	15
6.6 Data buffering	15
7. Connecting the transducers.....	16
7.1 Transducers	16
7.2 Measuring inputs and additional channels	16
7.3 Extending the measuring points	17
7.4 Potential separation	18
8. Relay trigger analog module.....	20
8.1 Power supply	20
8.2 Interface elements and options.....	20
8.2.1 Relays	21
8.2.2 Trigger inputs	21

8.2.3	Analog outputs	21
8.2.4	Connecting peripheral equipment.....	22
8.2.5	Putting into service.....	22
8.3	Technical data RTA5	22
9.	Operation and configuration	23
9.1	Combination key	23
9.2	Status LEDs	23
9.3	Device address and networking.....	23
9.4	Configuration.....	24
10.	Measured data acquisition	25
10.1	Online measurement with PC	25
10.2	Offline measurement.....	25
10.2.1	Sleep mode	26
10.2.2	Device-internal measured value memory (option S)	26
10.2.3	Memory connector with memory card.....	27
11.	Special measuring ranges, linearization, multi-point calibration	29
12.	Troubleshooting	30
13.	Declaration of conformity	32
14.	Appendix	33
14.1	Technical data	33
15.	Index	35
	Your contact	36

3. GENERAL

Congratulations on your purchase of this new and innovative ALMEMO® data acquisition system. Thanks to the patented ALMEMO® connector the device configures itself automatically and thanks to the supplied AMR-Control software its operation should be fairly straightforward. The device can, however, be used with such a wide range of sensors and peripherals and offers so many different special functions. You are advised therefore to properly familiarize yourself with the way the sensors function and with the device's numerous possibilities and take the time to carefully read these operating instructions and the appropriate sections in the ALMEMO® Manual. This is absolutely necessary to avoid operating and measuring errors and to prevent damage to the device. To help you find the answers to your questions quickly and easily there is a comprehensive index at the end both of these instructions and of the Manual.

3.1 Warranty

Each and every device, before leaving our factory, undergoes numerous quality tests. We provide a guarantee, lasting two years from delivery date, that your device will function trouble-free. Before you send your device to us, please observe the advisory notes in Chapter 12. Trouble-shooting In the unlikely event that the device proves defective and you need to return it please wherever possible use the original packaging material for dispatch and enclose a clear and informative description of the fault and of the conditions in which it occurs.

This guarantee will not apply in the following cases :

- The customer attempts any form of unauthorized tampering and alteration inside the device.
- The device is used in environments and conditions for which it is not suited.
- The device is used with unsuitable power supply equipment and peripherals.
- The device is used for any purpose other than that for which it is intended.
- The device is damaged by electrostatic discharge or lightning.
- The user fails to observe and respect the operating instructions.

The manufacturer reserves the right to change the product's characteristics in the light of technical progress or to benefit from the introduction of new components.

3.2 *Scope of delivery*

When you unpack the device check carefully for any signs of transport damage and that delivery is complete:

Measuring instrument ALMEMO® 5690-1M,
Mains adapter ZB 1212-NAx 12V/2.5A,
these operating instructions,

In the event of transport damage please retain the packaging material and inform your supplier immediately.

3.3 *How to deal with rechargeable batteries (option)*



Usually when the device is delivered the batteries have not yet been charged. First of all therefore the batteries should be charged using the mains adapter provided; continue charging until the **CHARGE** lamp goes out.

Rechargeable batteries must never be short-circuited or thrown on the fire.

Rechargeable batteries are special waste and must not be discarded together with normal domestic waste !

3.4 *Special notes on use*

- If the device is brought into the work room from a cold environment there is a risk that condensation might form on the electronics. In measuring operations involving thermocouples pronounced temperature changes may cause substantial measuring errors. You are advised therefore to wait until the device has adjusted to the ambient temperature before starting to use it.
- Before using the mains adapter make sure that the mains voltage is suitable.
- Be sure to observe the maximum load capacity of the sensor power supply.
- Sensors with power supply are not electrically isolated from one another.
- Do not run sensor lines in the vicinity of high-voltage power cables.
- Before you touch any sensor lines, ensure that all static electricity has been discharged.

4. INTRODUCTION

The data acquisition module ALMEMO® 5690-1M is a new member in our family of unique measuring devices - all equipped with Ahlborn's patented ALMEMO® connector system. The intelligent ALMEMO® connector offers decisive advantages when connecting sensors and peripherals because all parameters are stored in an EEPROM located on the connector itself; repeat programming is thus no longer necessary.

All sensors and output modules can be connected to all ALMEMO® measuring instruments in the same way. Programming and functioning are identical for all units. The following points apply to all devices in the ALMEMO® measuring system; these are described in detail in the ALMEMO® Manual which is included in delivery with each device:

- Detailed explanation of the ALMEMO® system (Manual Ch 1)
- Overview of the device functions and measuring ranges (Manual Ch 2)
- Basic principles, operation, and technical data for all sensors (Manual Ch 3)
- Options for connecting your own existing sensors (Manual Ch 4)
- All analog and digital output modules (Manual 5.1)
- Interface modules RS-232, optic fiber, USB, Ethernet (Manual 5.2)
- The whole ALMEMO® networking system (Manual 5.3)
- All functions and their operation via the interface (Manual Ch 6)
- Complete list of interface commands with all the printouts (Manual Ch 7)

The operating instructions you are now reading cover only those features and controls that are specific to this device. Many sections therefore also refer to the more detailed description in the Manual; (see Manual, Section xxx).

4.1 Functions of the ALMEMO® 5690-1M

The data acquisition system ALMEMO® 5690-1M has basically 9 electrically isolated measuring inputs with over 70 measuring ranges - suitable for all ALMEMO® sensors. This number can, using various selector switch boards, be extended to 99 inputs. To accommodate these various expansion stages the desktop housing is available in 12-DU / 32-DU / 84-DU sizes and a 19-inch rack is available. Thanks to the real-time clock incorporated as standard and the external memory connector with multimedia card the amount of data you can record is virtually endless. A variant is available with an integrated 512-KB EEPROM memory sufficient for approx. 100,000 measured values. There are two output sockets which can be used to connect any ALMEMO® output modules, e.g. analog output, digital interface, memory connector, trigger input, or alarm contacts. Several devices can be networked by simply connecting them with network cables.

The system is fed by default via a 12-V mains adapter. There is also the option of connecting a rechargeable battery module.

4.1.1 Sensor programming

The measuring channels are programmed, completely and automatically, by the ALMEMO[®] connectors. However, the user can easily supplement or modify this programming via the interface.

Measuring ranges

Appropriate measuring ranges are available for all sensors with a non-linear characteristic, e.g. 10 thermocouple types, NTC and PT100 probes, infrared sensors, and flow transducers (rotating vanes, thermoanemometers, Pitot tubes). For humidity sensors additional function channels are available for calculating humidity variables such as dew point, mixture ratio, vapor pressure, and enthalpy. Even complex chemical sensors are supported. Measured values from other sensors can also be acquired using the voltage, current, and resistance ranges with individual scaling in the connector. Existing sensors can also be used - so long as the appropriate ALMEMO[®] connector is connected via its screw terminals. For digital input signals, frequencies, and pulses, adapter connectors are available with an integrated microcontroller. It is thus possible to connect virtually any sensor to any ALMEMO[®] measuring instrument and to change sensors without the need for any extra settings.

Function channels

Maximum, minimum, average values and differences from certain measuring points can be programmed as function channels, also internal channels, and can be processed like normal measuring junctions. There are also function channels available for special measuring tasks, e.g. to determine the temperature coefficient $Q/\Delta T$ and wet bulb globe temperature.

Units

The 2-character units display can be adapted for each measuring channel so that both and via interface always indicate the correct units, e.g. when a transmitter is connected. Conversion between °C and °F is performed automatically.

Measured value designation

Each sensor is identified by means of a 10-character alphanumeric name. This name is entered via the interface and will appear via interface and in the software.

Correction of measured values

The measured value on each measuring channel can be corrected both in terms of zero-point and gain; this means that even sensors usually requiring initial adjustment (e.g. expansion, force, pH) can be freely interchanged. Zero-point correction and, partly at least, gain adjustment can be performed at the touch of a button.

A **new** feature is the possibility of user-defined linearization or multi-point calibration; (see 11).

4. Introduction

Scaling

The corrected measured value on each measuring channel can also be further scaled in terms of zero-point and gain - using the base value and factor. The decimal point position can be set by means of the exponent function. The scaling values can be calculated automatically by setting to zero and entering the nominal setpoint.

Limit values and alarm

Per measuring channel two limit values can be set (1 maximum and 1 minimum). In the event of one of these limit values being exceeded relay output modules actuate the associated alarm contacts; these can be allocated individually to specific limit values. Hysteresis is set by default to 10 digits but this can be adjusted to any number between 0 and 99. The exceeding of a limit value can also be used to start or stop measured value recording automatically.

Sensor locking

All sensor data stored in the connector EEPROM can be protected by means of a graduated locking function against undesired access.

4.1.2 Measuring operations

For each transducer up to four measuring channels are available; i.e. it is also possible to evaluate double sensors, individually scaled sensors, and sensors with function channels. All activated measuring points are continuously scanned at a rate of 2.5 measuring operations per second. The selected measuring point (M0) has preferred status, i.e. is rescanned each 2nd time (semi-continuous mode). The data is output via the interface and, if available, to an analog output. To shorten the response time when there are many measuring points this rate can be set to continuous and increased up to maximum 100 measuring operations per second.

Measured values

Measured values are acquired automatically with auto-zero and self-calibration; however, they can also be freely corrected and scaled as required. With most sensors a sensor breakage is detected automatically.

Analog output and scaling

Each measuring point can be scaled, by means of analog start and analog end, in such a way that the measuring range thus defined covers the full range of the analog output (2 V, 10 V, or 20 mA). At the analog output the device can output the measured value from any measuring point or a programmed value.

Measuring functions

With some sensors, to achieve optimal measured value acquisition, certain special measuring functions are required. Cold junction compensation is provided for thermocouples; temperature compensation is provided for dynamic pressure, pH, and conductivity probes; and atmospheric pressure compensation is provided for humidity sensors, dynamic pressure sensors, and O₂ sen-

sors. On infrared sensors the parameters for zero-point correction and gain correction are used as the background temperature and the emissivity factor.

Maximum and minimum values

Each measuring operation acquires and stores the maximum and minimum values with date and time-of-day. Each of these values can be output, used as function channel, or deleted.

Average value

Manual averaging is available per channel over a certain period or cycle or over a series of individual measurements.

4.1.3 Process control

To record the measured values from all connected sensors in digital form measuring point scanning is performed continuously with measured value output according to a time-based process control. This may be per output cycle or, if really rapid results are required, per measuring rate. The measuring operation can be started and stopped by means of a key, the interface, an external trigger signal, the real-time clock, or a limit value being exceeded.

Date and time-of-day

All measuring operations can be accurately logged using the real-time clock with date function or in terms of the pure measuring time. For the purposes of starting / stopping a measuring operation, the start / stop date and time-of-day and / or the actual measuring duration can be programmed.

Cycle

The cycle can be programmed to any value between 00:00:01 (1 second) and 59:59:59 hh:mm:ss. This function permits cyclic output of measured values to the interfaces or to the memory and provides cyclic calculation of the average value.

Print cycle factor

The print cycle factor can be used to limit data output from particular channels; this may be necessary in order to reduce excessive data flow especially during data storage.

Averaging over measuring point scans

The measured values from measuring point scans can be averaged either over the whole measuring duration or over the specified cycle. Function channels are available for the cyclic output and storage of these average values.

Measuring rate

The available measuring rates are 2.5, 10, 50, or 100 measuring operations per second (100 being subject to certain restrictions). Recording can be accelerated if all measured values are stored to memory and / or output to the interface at the full measuring rate.

Measured value memory

To save measured values there are two alternative methods. Option S is a

4. Introduction

512-KB non-volatile EEPROM, sufficient for up to 100,000 measured values. This memory can be organized and configured in linear or ring form. Output is via the interface. Selection can be specified according to a time interval or number.

New : Or alternatively, without option S, an external memory connector with memory card can simply be connected at socket A2. This solution, depending on the size of the card, offers a virtually limitless memory capacity. With an external memory connector, available as an accessory, files can be read out very quickly via any standard card reader.

Numbering of measuring operations

By entering a number, single scans or entire series of measuring operations can be identified and selectively read out from the memory.

Control outputs

Via the interface up to four output relays and analog outputs can be individually addressed.

Output

All measurement logs, all saved measured values, and all programming parameters can be output to any peripheral equipment. USB-, RS232, RS422 and Ethernet interfaces are available via the appropriate interface cables. Wireless communication is also possible via radio. Measured data can be output in list, column, or table format. Files in table format can be processed directly using any standard spreadsheet software. The print header can be programmed specifically for the company or application.

Networking

All ALMEMO[®] devices can be addressed and can be easily networked by simply linking them together via network cable or for longer distances via RS422 network distributors.

Software

Each ALMEMO[®] Manual is accompanied by the AMR-Control software package, which can be used to configure the measuring instrument, to program the sensors, and to read out from the measured value memory. Using the integrated terminal, measuring operations can also be performed online. The WINDOWS[®] software package WIN-Control is provided for the purposes of measured value acquisition via networked devices, for graphical presentation, and for more complex data processing.

5. INITIAL COMMISSIONING

1. **Sensor connection** : Plug in sensor at sockets **M0** to **Mxx** (2c); see Sec. 7.
 2. **Power supply** : Connect mains adapter at socket **DC** (2g); s. Sec. 6.1.
 3. **Switching on** : Press the **ON** key (2e); see Section 6.5.
 4. **Device configuration by PC via the interface** :
Connect computer via interface cable to socket A1 (2f); see Manual 5.2.
Activate the software, e.g. the supplied AMR-Control.
Identify the device by means of <Search network>,
If the device is not found select <Setup interface>.
Set the COM interface and baud rate to 9600 baud; (see Manual 6.1.1.)
<Update list> <Program device>
Input "cycle" for automatic measuring point scan; see Manual 6.5.2.
Activate "With memory" to save (only with option S or memory connector)
if necessary "Accept date and time-of-day from PC"; see Manual 6.2.8.
Program the output format; see Manual 6.5.5 and 6.6.1.
"Table" for MS-Excel / "List" or "Columns" for text editor
 5. **Measured data acquisition from PC without saving in device** :
Activate <File - terminal>; see Manual 6.1.3.
<Open file - terminal - log>, enter file name, "Save"
Start measuring operation by the "Start" button or the **START/ STOP** key;
Stop measuring operation by the "Stop" button or the **START/ STOP** key.
<Close file - terminal log>
Activate file e.g. from MS-Excel and import using ";" as separator;
 6. **Saving meas. values in the device** : (only with option S or memory connector)
Activate <Measured value memory>.
If necessary "Clear memory" "Execute"; see Manual 6.9.3.
For long-term recording (cycle > 2 minutes) Activate sleep mode; s. Sec. 10.2.1.
"Start saving to memory" immediately or
start measuring operation on site by pressing the **START/ STOP** key.
or in <Program device> enter measuring operation "Start date / time" and "End date / time"; see Manual 6.6.2.
At the end of the meas. operation stop recording by the **START/ STOP** key.
- Transferring data from memory to the computer**
If you are using a memory connector remove the memory card and transfer via a USB reader to the PC (see Manual 6.9.4.2) or
reconnect the computer via the interface cable at socket A1 (2f); see above.
In AMR-Control activate <Measured value memory>.
Click on "Read out complete memory".
Set "Format"; see above.
Read out "Execute", enter file name, "Save"; see Manual 6.9.3.
Activate file e.g. from MS-Excel and import using ";" as separator;

6. POWER SUPPLY

Power can be supplied to the instrument in any of the following ways :

- Mains adapter 12V/2.5A (ZB 1212-NAx)
- Electr. isol. power supply cable, 10 to 30 VDC, 0.25 A (ZB 3090-UK)
- Electr. isol. power supply cable, 10 to 30 VDC, 1.25 A (ZB 3090-UK2)
- Rechargeable battery module, NiMH 9.6 V / 1600 mAh (ES 5690-AP)

See product overview, Annex 14 and the following chapters.

6.1 Mains operation

To power the device from the mains use the mains adapter provided, 12 V / 2.5 A (ZB 1212-NAx). The mains adapter must be connected to the DC socket (2g) and locked by twisting to the right.

If necessary the device can also be grounded via the bare socket (6h) (e.g. protective ground connector).

6.2 External DC voltage supply

The **DC** socket (2g) can also be used to connect another DC voltage, 10 to 13 V (minimum 200 mA). For this connection use a cable with 2 banana plugs (ZB 5090-EK). If, however, the power supply has to be electrically isolated from the transducers or if a larger input voltage range, 10 to 30 V, is required, then electrically isolated supply cable (ZB 3090-UK) must be used (or ZB 3090-UK2 with the rechargeable battery module). It will then be possible to use the measuring instrument in a 12-volt or 24-volt on-board supply system.

6.3 Operation with rechargeable battery (only with module ES5690-AP)

For mains-independent operation the system must be equipped with module AP with eight NiMH rechargeable batteries (9.6 V / 1600 mAh). At a current consumption of approx. 25 mA this will give an operating time of approx. 60 hours. To prolong the operating time for the purposes of long-term recording the device can be left in SLEEP mode; (see 10.2.1). When the remaining capacity of the rechargeable batteries drops to approx. 10%, the **ALARM** LED in the display will start flashing; as soon as this happens the batteries must be recharged. If the batteries are completely discharged the device will switch off to avoid the risk of critically low discharge. The measured data and time-of-day will, however, be retained; see 6.6. The NiMH rechargeable batteries can in fact be recharged at any time and in any charge status using the intelligent charge circuitry. To charge the batteries the mains adapter, 12 V / 2.5 A (ZB 1212-NAx) must be connected to socket **DC-A** (1a) on the battery module. The "**CHARGE**" lamp should then light up indicating that the batteries are being recharged. After approx. 3.5 hours the batteries are fully recharged and the LED goes out again. After a certain period the batteries are recharged again; the charge circuitry then switches over to trickle charge. The mains adapter can thus be left permanently connected to the measuring instrument in buffer

mode without risk of overcharging the batteries. If you prefer not to recharge the batteries, e.g. to prevent the device from warming up during thermocouple measurement, you can connect the mains unit to the **DC** socket (2g).



If you intend to replace the rechargeable batteries yourself please be absolutely sure that you change all of them and that the new batteries provide the same capacity; failure to heed this advice may cause high-speed charging to malfunction and the batteries may be damaged.

6.4 Sensor supply

During mains operation there is, on terminals + (plus) and – (minus) in the ALMEMO® connector, a sensor supply voltage available, 12 V, 400 mA (self-healing fuse, 500 mA). During battery operation the battery voltage is available, 9 to 11.5 V. Other voltages (12, 15, or 24 V or references for a potentiometer and strain gauge) can be obtained using special connectors; (see Manual 4.2.5 and 4.2.6).

6.5 Switching ON / OFF,

To switch the device **ON** press the **ON-OFF** key (2e); if all is in order the "ON" lamp should light up.

To switch the device **OFF** press the **ON-OFF** key and hold down for approx. 1 second. After the device is switched off the real-time clock continues to run and all saved values and settings are retained intact; (see 6.6).

If the device behaves abnormally as the result of interference (e.g. electrostatic or mains failure), you are advised try first of all to clear the problem simply by reinitializing, i.e. switching off and then on again.

If this does not help then you are advised to restore all device programming to the factory default settings. The device can be **reset** by setting the code switch **G** (2d), before switching on, to address 99. This has the effect of also resetting the baud rate setting on the data cable to 9600 baud. However, the programming of the sensors in the ALMEMO® connectors always remains intact.

6.6 Data buffering

The sensor's programming is stored in the EEPROM on the sensor connector and the device's calibration and programmed parameters are stored in the EEPROM on the instrument itself, both on a fail-safe basis. The memory data is also saved in non-volatile EEPROMs. The date and time-of-day are buffered by a dedicated lithium battery; even when the device is switched off and without batteries this data is retained intact for years.

7. CONNECTING THE TRANSDUCERS

Virtually any ALMEMO[®] sensor can be connected to the input sockets on ALMEMO[®] modules types (2) and (3). To connect your own existing sensors you simply need the appropriate ALMEMO[®] connector. Other compact modules are described below.

7.1 Transducers

The ALMEMO[®] Manual includes detailed descriptions of the comprehensive ALMEMO[®] range of sensors (see Manual Ch 3) and instructions for connecting your own existing sensors to ALMEMO[®] instruments (see Manual Ch 4). All standard sensors with an ALMEMO[®] connector usually have the measuring range and units already programmed and can thus be connected to any input socket without further adjustment. A mechanical coding system ensures that sensor and output modules can only be connected to the correct sockets. All ALMEMO[®] connectors incorporate two snap-lock levers; these snap into position as soon as the connector is inserted into the socket, thus preventing unintended disconnection if the cable is accidentally pulled. To withdraw the connector, both these levers must be pressed in at the sides.

7.2 Measuring inputs and additional channels

Measuring circuit board MM-A9 has 9 input sockets (2c) to which initially measuring channels M0 to M8 are allocated. However, ALMEMO[®] sensors can, if required, provide up to 4 channels with 9 input sockets each so that altogether 36 channels are available. The additional channels can be used in particular for humidity sensors with four measuring variables (temperature / humidity / dew point / mixture ratio) or for function channels. Each sensor can if necessary be programmed with several measuring ranges or scaling settings; and two or three sensors, if pin assignment so permits, can be combined in a single connector (e.g. rH / Ntc, mV / V, mA / V, etc.). The additional measuring channel numbers per connector go up in steps of 10 (e.g. the first sensor has channels M0, M10, M20, M30, the second sensor has channels M1, M11, M21, M31 etc.).

Device-internal channels:

A further innovation on this device is its four additional device-internal channels. The first of these M9 is programmed by default as differential channel M1 – M0. This only happens, however, if there are two sensors with the same units and same decimal point position connected at measuring points M0 and M1. However, all four channels can be programmed with any other function channels (e.g. U-Bat, VK, average, volume flow, etc.); (see Manual 6.3.4). The reference channels used are by default Mb1 = M1 and Mb2 = M0 but this can be modified (see Manual 6.3.4).

The **advantage** of device-internal channels is that when using several sensors for the same application these sensors do not have to be reprogrammed and can be exchanged without losing the function channels. However, if the whole application operates with just one sensor, then programming on the sensor itself makes more sense.

On the measuring circuit board this gives the following channel assignment:

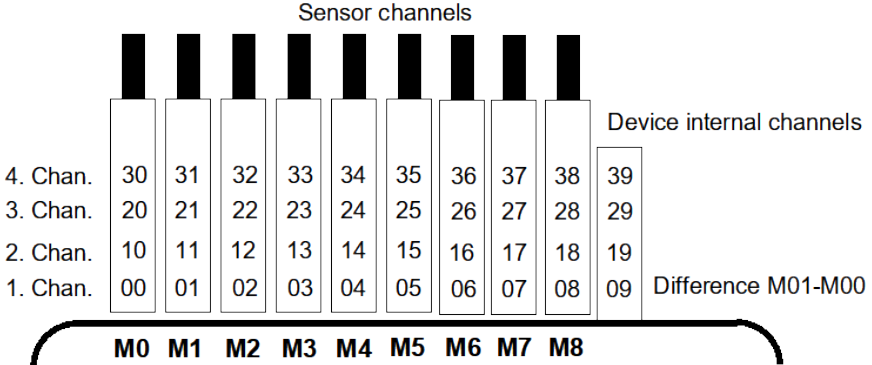

7.3 Extending the measuring points

To **extend the measuring points** up to 9 passive selector switch boards can be used; however, the total number of measuring channels is limited to maximum 100.

The **master measuring circuit board** MM-A09 (2) can also drive up to **9 selector switch boards** with 10 inputs each, and these can in turn be switched by photovoltaic relays. The sensor and channel number of each module can be adapted to individual requirements by configuring the measuring point numbering and thus the channel number of the modules by means of a code switch (3j). This code switch defines the measuring point number of the first measuring point of each module and thus also the channel number of the previous module. This measuring point number must logically be set between 10 and 40 measuring points higher than the previous module and accordingly the channel number of the previous module will be limited to 10 to 40 measuring points. Multi-channel sensors should therefore be collected as far as possible in one module. 100 sensors can only be collected in 10 modules if the channel number of each module is limited to 10, i.e. the measuring point number goes up by 10 each time. The time taken for a measuring point scan increases in proportion to the number of measuring channels.

1. With selector switch boards U-A10 (3) the number of measuring points is extended each time by 10 electrically isolated ALMEMO[®] inputs for all ALMEMO[®] sensors. In the housing each module occupies 2 plug-in slots. For the purposes of thermocouple measurement each module is equipped with 2 cold junction sensors whose value is interpolated for each measuring point. The measuring time involved will affect the total sampling rate.
2. The selector switch board U-MU (4) occupies only 1 plug-in slot but it too has 10 inputs led out to a 64-contact socket strip. The sensors are connected via a 10-fold connector (ZA 5690-MU) each with four screw terminals A, B, C, D, in the same way as any standard ALMEMO[®] connector;

7. Connecting the transducers

(see Manual 4.1). Sensors requiring a power supply or an ALMEMO® connector with special interface circuitry (e.g. humidity sensors, rotating vanes, etc.) cannot be connected in this way. The new connector ZA 5690-MU with a larger EEPROM now permits 4 channels per sensor, i.e. 40 channels altogether; on the old connector ZA 5590-MU there are only 10 channels available. Measuring point numbering is as described above, namely by means of a code switch internally on the board. For this purpose the module must be withdrawn and the number on the switch multiplied by 10 (4 = measuring point 40). All sensors can be programmed individually but their programming data is all saved together in a common EEPROM located in the connector. A cold junction sensor is also provided for thermocouples. Two limit value relays, operating separately for maximum and minimum, can be contacted in the connector; these can only be used with an appropriate selector switch board option.

3. Selector switch board U-TH (5) has 10 inputs for thermocouples with a thermal connector. The sensor data is saved to an EEPROM on the board; automatic sensor recognition is therefore not possible. Measuring point numbering is by means of the code switch internally on the board (see above). This module occupies only 1 plug-in slot but if arranged in series one dummy panel must be inserted between in order to operate the connector.
4. (6) also has 10 inputs; these are led directly onto two 20-contact plug connectors with terminals. Sensors can be connected via terminals A, B, C, D, with the familiar wiring arrangement. In order to feed in the wires the outside connectors must be opened by inserting a narrow screw-driver in the inside holes. Or alternatively the cards are available with shunts for 20-mA signals (terminals A and B, 'mA' or '%') or with dividers for 10-V signals (terminals A and C, 'mV 2'). This module is only suitable for thermocouples if these are connected with copper wires via an isothermal block with integrated cold junction sensors; (see Manual 6.7.3). The sensor data is saved to an EEPROM on the board; automatic sensor recognition is therefore not possible. Measuring point numbering is by means of a code switch internally on the board (see above). This module occupies 1 plug-in slot only.

7.4 Potential separation

When organizing a properly functioning measuring setup it is very important to ensure that no equalizing current can flow between sensors, power supply, and peripherals. This will be the case so long as all points lie at the same potential or unequal potentials are electrically isolated.

7. Connecting the transducers

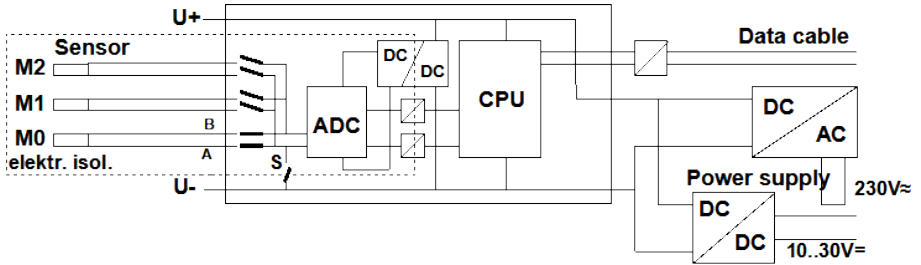

The analog inputs are electrically isolated from one another by means photo-voltaic relays. A new feature on this device is the additional separation of the measuring inputs from CPU and power supply. Between all inputs and outputs (even the analog output cables which are not electrically isolated) the maximum potential difference permitted is 50 V. The voltage at the measuring inputs themselves must not exceed 12 V (between B, C, D, and A).

However, some components are not electrically isolated, namely all sensors connected to the same common internal power supply $\pm U$ or combined sensors within one connector. For these sensors the electrical isolation may have to be disabled by means of relay S (see above) or by wire jumper; some inputs would otherwise be left without reference potential. The relay is set automatically by element flag 5 'ISO OFF' the first time it is connected; (see Manual 6.10.3). However, with certain connectors (especially divider connectors without power supply) element flag 5 should be checked and if necessary corrected. These sensors must themselves be isolated or the device must be operated with an electrically isolated power supply (mains adapter or connecting cable ZA2690-UK with DC/DC converter).

Data and trigger cables are also isolated by means of optocouplers.

8. RELAY TRIGGER ANALOG MODULE

The universal trigger output interface specially provided for ALMEMO® 5690 systems is relay trigger analog module ES 5690-RTA5 with up to 10 interface elements (4 semiconductor relays and 2 trigger inputs as standard but optionally up to 10 semiconductor relays or 10 electrically isolated analog outputs).

Up to maximum 7 modules can be simply plugged into a free slot, preferably after the measuring inputs; they will be detected and recognized automatically as soon as the system is powered up. All 10 interface elements of each module can in the 'OutPut modules' menu be individually selected and configured as ports P0 to P9. (see 12.6.2)

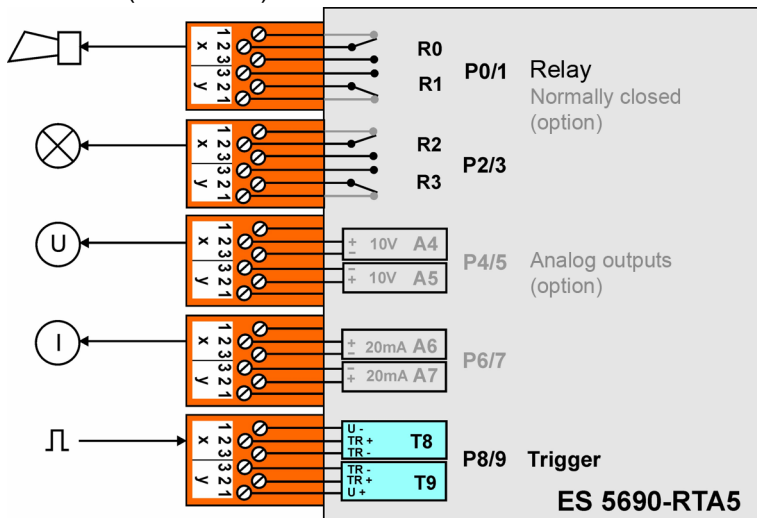

8.1 Power supply

The adapter is supplied with a voltage of 9 to 12 VDC via the system itself. In the standard version the maximum requirement is 20 mA. It is only with optional analog outputs, in particular with electric current outputs, that the maximum supply current per module must be observed. (see 9.3)

8.2 Interface elements and options

Sockets P0/1 and P2/3 are fitted as standard with four semiconductor relays, normally open type; socket P8/9 is fitted as standard with two trigger inputs. Option OA 8006-OH2 provides each relay pair with two additional semiconductor relays, normally closed type.

Option OA 8006-SH2 can be used in each case to retrofit two further relays (up to maximum 10), including ALMEMO® clamp connectors.

Option OA 8006-R02 can be used to equip the sockets - initially P4/5 and P6/7 but subsequently also all others - with analog outputs 0 to 10 V or 0 to 20 mA electrically isolated, including ALMEMO® clamp connectors.

8.2.1 Relays

The output relays are driven by means of interface commands or in the event of alarm automatically by the system. (see Manual, 6.10.10) The function of each relay can be freely set by configuration. (see 12.6.2) The assignment of a limit value to a relay can be programmed in the sensor by the device. (see 12.4.3) Whenever a relay is activated a short acoustic alarm is sounded. The way in which these relays are driven can be configured as inverted so that they pick up in normal conditions and drop out in the event of alarm or power failure.

In the following cases it is advisable to connect a mains voltage changeover relay downstream (e.g. Phoenix PLC-RSC-24DC/21, 250V 6A).

- ▶ Current or voltage capacity greater than 50 V, 0.5 A
- ▶ For separating the mains voltage side
- ▶ For the realization of an alarm failure of the control side

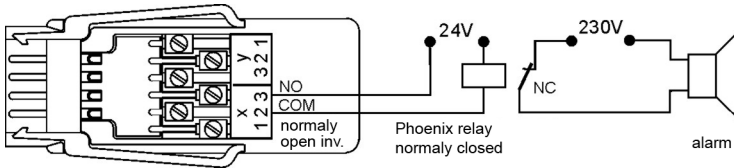

8.2.2 Trigger inputs

Trigger inputs P8 and P9 can be driven via optocouplers on the basis of voltage levels (4 to 30 V). When using floating switch contacts the optocouplers must be appropriately wired with supply U+ and U-. (see diagram)

The trigger function (as standard to start or stop a measuring operation) can also be freely configured. (see 12.6.2)

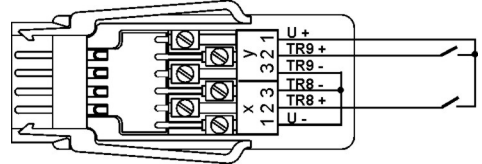

8.2.3 Analog outputs

In various options the module can also be fitted with electrically isolated analog outputs, offering the following signals.

Option	Output signal	Gain
OA 8006-R02	0.000 to +10.000 V	0.5 mV / digit
or	0.000 to +20.000 mA	1 μ A / digit

The output value normally corresponds to the measured value for the selected measuring point. Or alternatively the analog value can be specified as control variable via the interface. (see Manual, 6.10.7) The output signal can in each case be programmed as standard output 0 to 10 V, 0 to 20 mA, 4 to 20 mA for any partial measuring ranges. (see 12.4.4, 12.6.3)

8. Relay trigger analog module

8.2.4 Connecting peripheral equipment

Peripherals can be connected via the supplied ALMEMO® screw connectors according to the following arrangements.

Terminals	P0/1 Relay	P2/3 Relay	P4/5 Analog (opt.)	P6/7 Analog (opt.)	P8/9 Trigger
y1	R1 n. closed (opt.)	R3 n. closed (opt.)	(opt.)	(opt.)	U+
y2	R1 Common	R3 Common	AO5 +	AO7 +	TR9+
y3	R1 n. open (opt.)	R3 n. open (opt.)	AO5 -	AO7 -	TR9 -
x3	R0 n. open (opt.)	R2 n. open (opt.)	AO4 -	AO6 -	TR8 -
x2	R0 Common	R2 Common	AO4 +	AO6 +	TR8+
x1	R0 n. closed (opt.)	R2 n. closed (opt.)			U -

8.2.5 Putting into service

1.The relay module should be plugged into a free slot in the ALMEMO® system; the integrated interface elements are then available as port P30 to P39.

2. The peripheral equipment should be connected to the clamp connector and plugged in on the relay module at the appropriate port sockets. see 9.2.4

4.All the programming functions can be performed via the device keypad in the "Output modules" menu (see 12.6.2) or using the AMR-Control software or via terminal commands. (see Manual, 6.10.9.2 and 6.10.10)

8.3 Technical data RTA5

Relays	Semiconductor relay 1 ohm, Load capacity 50V, 0.5A
Trigger inputs	Optocoupler 4 to 30 V, Input current 2 mA
Analog outputs	electrically isolated, optionally
OA 8006-R02	0.00 to +10.0 V, 0.5 mV / digit, Load >100 kΩ 0.0 to +20.0 mA, 1 μA / digit, Load <500 Ω
Accuracy	±0.1% of final value
Temperature drift	10 ppm / K
Time constant	100 μs
Power supply	9 to 12 VDC from the measuring instrument
Current consumption	Standard approx. 10 to 20 mA For each 2 analog outputs appr. 15 mA + 1.75 x I _{out}
Housing	19" plug-in device 8 DU

9. OPERATION AND CONFIGURATION

Data acquisition system ALMEMO® 5690-1M has only a few operating controls; it is operated mainly via a PC.

9.1 Combination key

The first function of the one and only key **ON/OFF-START/STOP** (2e) on the master measuring circuit board has already been described in Section 6.5.

Press to switch ON and press and hold down to **switch OFF again**.

If the device is on and a cycle has been programmed the same key can be used to **start** and **stop** a measuring operation.

The current operating status is clearly shown by the LEDs.

9.2 Status LEDs

The following LEDs (3) report the device status :

ON	Device is on.
ON flashes once briefly	Device is in sleep mode.
START continuous	Measuring operation is started.
COM continuous	Measured value transmission to the PC - cyclic
COM flashes	Measured value to the PC - at the conversion rate
REC continuous	Cyclic measuring point scan with data saving Also lights up during memory output
REC flashes	Data saving at the conversion rate
START flashes once briefly	Once-only measuring point scan from PC
COM flashes once briefly	Once-only meas. point scan transfers data to PC
REC flashes once briefly	Once-only measuring point scan with data saving
ALARM	Limit value exceeded or sensor breakage
ALARM flashes once briefly	Device supply voltage too low

9.3 Device address and networking

ALMEMO® 5690-1M systems, like all ALMEMO® devices, can also be networked. To communicate with networked devices it is absolutely indispensable that each device should have its own dedicated address; this is because only one device should respond per command. Before each network operation therefore all measuring instruments must be set, by means of their code switches (1), to different device numbers

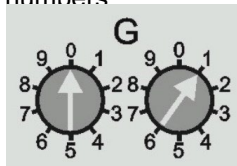

Example: Module address 01 0 1



In network operation consecutive numbers between 01 and 99 should be used; this ensures that device 00 is not addressed unnecessarily in the event of interruption to the power supply.

9. Operation and configuration

9.4 Configuration

For the purposes of programming and configuration the supplied AMR-Control software is ideally suited. This can be used to modify the the programming of the sensors and to configure the process control. The various possibilities are explained in detail in the Manual Ch 6. This Chapter also describes how all functions can be programmed via a terminal by means of ASCII commands.

10. MEASURED DATA ACQUISITION

Measured data acquisition can be performed in basically two ways :

1. Perform measurement online and transfer data to the PC immediately (no device-internal memory required).
2. Perform measurement offline, i.e. the data is first saved to the device memory (option S) or to an external memory connector with multimedia card and then transferred to the PC later.

10.1 Online measurement with PC

For conveniently recording measured data on the PC the measured data acquisition software Win-Control is ideally suited. It is unique in that it can scan one stand-alone or several internetworked measuring modules at its own measuring cycle, then save the measured data on the PC, and output it online in a clearly understandable form as a line diagram, table, or list; thus for process control purposes just program the measuring cycle in Win-Control. There are numerous other possibilities using formula channels, control and regulation functions, alarm reports via SMS and e-mail, etc. but it would be going too far to describe all these here in detail.

10.2 Offline measurement

To perform offline measuring operations, i.e. data logging in the device itself, you need either option S with a 500-KB EEPROM on the master measuring circuit board or an external memory connector with a memory card (ZA 1904-SD) connected at A2 (2f). It is an indispensable prerequisite that the following parameters be configured :

1. Date, time-of-day
2. Cycle with saving to memory activated
3. Sleep mode, possibly

The easiest way to do this is by means of the AMR-Control software, in menu <Program device>. If necessary you can clear the memory in the menu <Data memory>.

To start and stop a measuring operation on site there are numerous methods available; (see Manual 6.6).

1. Press the **START / STOP** key (2) on the device.
2. Program the start date and time-of-day and then either the end date and time-of-day or the measuring duration (see Manual 6.6.2).
3. Reaction to overshooting / undershooting a limit value (see Manual 6.6.3).
4. Triggering in response to electrical signals (see Manual 6.6.4).

The status of a measuring operation and of data recording can easily be traced by watching the LEDs (see 9.2).

To read out the measured data (see Manual 6.9.3) select AMR-Control menu item <Devices - Data memory>. Here you can transfer to a file on the PC either the complete memory or parts of it selected according to date and time-of-day or by number; the device memory can then be cleared.

10. Measured data acquisition

10.2.1 Sleep mode

For long-term monitoring involving large measuring cycles where power is supplied by rechargeable or normal battery the measuring system can also be operated in sleep mode. In energy-saving sleep mode the measuring instrument switches off after each measuring point scan and switches on again automatically after the cycle expires ready for the next measuring point scan. In this way with just one battery recharge up to 30000 measuring point scans can be performed; for a cycle lasting 5 minutes this represents a measuring capability of over 100 days.

For a **data recording in sleep mode** go to AMR-Control <Device programming> and take the following steps :

1. Enter a cycle lasting at least two minutes.
2. Activate saving to memory in the cycle.
3. Activate sleep mode.
4. Start measuring operation as normal; the device should then switch off; as a check the LED 'ON' (3) should flash rhythmically on and off.
6. In the specified cycle the instrument switches on automatically, performs one measuring point scan, and then switches off again.
7. Terminating a measuring operation key twice presses (2e), function 'ON' and 'STOP'.

In this way any number of measuring operations can be performed in sleep mode up until when sleep mode is deactivated again. With cycles shorter than 2 minutes measuring operations are performed automatically in normal mode.

10.2.2 Device-internal measured value memory (option S)

With option S the master measuring circuit board of system 5690-1M incorporates a memory with a 512-KB EEPROM, sufficient for 64000 to 100000 measured values (depending on the number of channels). This memory is non-volatile; i.e. it retains data intact even in the event of a failure affecting the lithium battery used to buffer the real-time clock. How this measured value memory is organized and how data is recorded to it and output from it are described in the Manual, Section 6.9. It can be configured either as linear memory or ring memory; (see Manual 6.10.13.2).

As on all other ALMEMO[®] data loggers the internal memory supports the following functions :

Recording to ring memory

Sleep mode

Data output in any normal format

Selective data output according to date and time

Selective data output by number

However, only one connector configuration is possible.

10.2.3 Memory connector with memory card

Another convenient feature for data recording without option S is provided by the newly developed memory connector (ZA 1904-SD) with a conventional memory card. The memory card measured data is written to it via the memory connector in table mode and in standard FAT16 format. The SD card can be formatted and its contents can be read and deleted via any normal PC using any card reader; see Manual 6.9.4.2. Measured data can be imported into MS-Excel or into Win-Control, the accompanying measured value software. The memory connector works in a completely different way to the device-internal memory; this brings both restrictions and advantages.

Functions of the memory connector with memory card:

Virtually unlimited memory capacity

With each new sensor configuration a new file is created.

No ring memory recording

Sleep mode

Data can be evaluated using any reader on site and elsewhere.

Very high-speed data transfer via the reader

Data recording and output in table format only

Via the ALMEMO[®] device itself only the last file can be read.

No selective data output according to date and time or by number

The memory connector with the memory card can be connected at socket A2 (2f); it is recognized automatically. If the external memory is connected at the start of any measuring operation, it will be used. In the course of the measuring operation it must not be unplugged; this would cause temporarily buffered measured values to be lost.

Before starting any measuring operation you can enter an 8-character file name (see Ch 11). In the absence of a user-assigned file name, the default name 'ALMEMO.001' or the name most recently used will be suggested automatically. So long as the connector configuration is not altered, you can save several measuring operations, either manually or cyclically, also with numerical assignment, all in the same file.

If, however, the **connector configuration** has been **changed** since the most recent measuring operation and if no new file name has been programmed, then a new file is always created and in so doing the index in the file name extension is automatically incremented by 1, e.g. 'ALMEMO.002'. Similarly, if the file name entered already exists, then a new file will be created with the same file name prefix but with a new index.



Please note : **If you clear the memory** the card will be **reformatted** ! (interface command C04)

Using a SD card to perform measuring operations at a rate of 100 mops in mains mode may - if the housing is not properly grounded - lead to measuring errors. In these circumstances we recommend that the ground socket on the device be connected to protective

10. Measured data acquisition

ground.

When plugging in the connector make sure that the card remains latched in position !

To check that the memory connector is **functioning properly** there is an LED incorporated in the end of the handle; this indicates the following states :

- No memory card detected : LED flashes once long and then three times short.
- Data is being recorded : LED flashes in the same rhythm as the cycle.
- Data is being read out : LED lights up continuously for the duration of data output

11. SPECIAL MEASURING RANGES, LINEARIZATION, MULTI-POINT CALIBRATION

Thanks to the new ALMEMO® special connectors with extra memory for additional data (bigger EEPROM, code E4) the following tasks can now be performed for the first time with great elegance :

1. Provision of special measuring ranges with internal characteristic
2. User-defined linearization of signals for voltage, current, resistance, or frequency
3. Multi-point calibration of all sensors
4. Serial number and calibration data management in the sensor

The 5690-1M system can as a standard feature evaluate all appropriately programmed special connectors but only on the master measuring circuit board. Special measuring ranges can be used on selector switch boards so long as they employ the same characteristic as channel M8. With option KL you can yourself, using the AMR-Control software, program a characteristic of up to 35 support values in the EEPROM on the ALMEMO® connector (menu <Measuring points> list <Program measuring point>, <Measuring point>, multi-point calibration / special linearization). During a measuring operation the measured values between these are interpolated on a linear basis. When correcting non-linear sensors (e.g. with PT100 or thermocouple sensors) initially the original characteristics are considered; then only the deviations are interpolated on a linear basis and inserted.

If a channel with a characteristic is deactivated or programmed with a different range, the characteristic is subsequently reactivated by restoring the special range by means of command 'B99'.

Other information that can be entered in the extended connector includes the order number, the serial number, the date of the next calibration, and the calibration interval. In internetworked systems this permits automatic monitoring of the calibration intervals; (for commands see Ch 11).

12. TROUBLESHOOTING

Data acquisition system ALMEMO[®] 5690-1M can be configured and programmed in many versatile ways. It is suitable for connecting a wide variety of very different sensors, additional measuring instruments, alarm signaling devices, and peripheral equipment. Given these numerous possibilities the device may in certain circumstances not behave quite as expected. The cause of such unexpected behavior is only very rarely a device defect; more usually it is incorrect operation by the user, an invalid setting, or unsuitable cabling. In such event try to pinpoint and clear the problem with the aid of the following tests.

Error: LED is not lit .

Remedy: Check the power supply, charge the battery, switch off and then on again. If necessary, re-initialize; (see 6.5).

Error: Measured values are incorrect.

Remedy: Check all the channel programming very carefully, especially the base value and zero-point (sensor programming and special functions).

Error: Fluctuating measured values or the system hangs in mid-operation.

Remedy: Check the cabling for any inadmissible electrical connections.

For sensors with their own power supply check element flag 5; (s. 7.4.)

Unplug any suspicious sensors. Connect hand-held sensors in air or phantoms (for thermocouples short-circuit AB, for PT100 sensors use 100Ω) and check. Connect the sensors again one at a time and check successively. If a fault persists for any one connection, then check all wiring; if necessary, insulate the sensor and eliminate interference by using shielded or twisted wiring.

Error: Data transmission via the interface does not function.

Remedy: Check interface module, connections, and settings.

Are both devices set to the same baud rate and transmission mode ? (see Manual 6.10.12). In the event of a reset (see 6.5) with the interface module connected the baud rate will be set to 9600 baud.

Is the correct COM interface on the computer being addressed ?

Are the handshake lines DTR and DSR active ? Test data transmission by means of a terminal (AMR-Control, WIN-Control, WINDOWS-Terminal)

Address the device using its assigned device number 'Gxy' s. Man 6.2.1 Enter <Strg Q> for XON, if the device is in the XOFF status.

Check the programming by means of 'P15' (see Manual 6.2.3).

Test only the transmit line by entering the start command 'S2'; LED **START** should light up.

Test only the receive line by pressing the **START / STOP** key.

Error: Data transmission in the network does not function.

Remedy: Check to ensure that all devices are set to different addresses.
Address all devices individually via the terminal with command 'Gxy'.
Addressed device is OK if at least 'y CR LF' is returned as echo.
If transmission is still not possible, unplug the networked devices.
Check all devices individually on the data cable to the computer;
Check the wiring for short-circuit or crossed wires.
Are all network distributors supplied with power ?
Network the devices again one at a time and check successively;
(see above).

If, after performing the above-listed checks and remedial steps, the device still fails to behave as described in the operating instructions, it must be returned to our factory in Holzkirchen, accompanied by an explanatory note, error description, and if available test printouts. With the AMR-Control software you can print out screen-shots with the relevant programming and save and / or print out a comprehensive 'function test' in the device list or terminal operations.

13. DECLARATION OF CONFORMITY



Doc-Nr. CE_MA56901M09_001_20181217_R1.doc

EU-Konformitätserklärung

EU-Declaration of Conformity

nach/according to EN 17050-1

Hersteller: Ahlborn Mess- und Regelungstechnik GmbH

Manufacturer:

Adresse: Eichenfeldstrasse 1

Address: 83607 Holzkirchen

Germany

**bestätigt, dass das Produkt
declares, that the product**

Produktbezeichnung:

Product Name:

Almemo® Messwerterfassungsanlage MA5690-1M09

Produkt Typ:

Product Type:

MA5690-1M09

Produkt Optionen:

Product Options:

Alle/all

den nachfolgenden Europäischen Anforderungen und Richtlinien entspricht und folglich das **CE** Zeichen trägt.

*conforms to following European Product Specifications and Regulations and carries the **CE** marking accordingly.*

2014/35/EU

Niederspannungsrichtlinie

Low Voltage Directive

2014/30/EU

EMV Richtlinie

EMC Directive

2014/53/EU

R&TTE Richtlinie

R&TTE Directive

Angewandte harmonisierte Normen

Sicherheit (Safety)

und technische Spezifikationen:

EN 61010-1: 2010+A1

Applied harmonised standards and

EMV (EMC)

technical specifications:

EN 61326-2-3: 2013 Tabelle 2

Holzkirchen, 17.12.2018

Ort, Datum der Ausstellung

Place, date of issue

Entwicklungsleitung

Qualitätsmanagement

14. APPENDIX

14.1 Technical data

Measuring inputs :

Master meas. circuit board MM-A9: 9 ALMEMO® sockets, suitable for ALMEMO® flat connectors
Measuring channels: 9 primary channels, electrically isolated, maximum 31 additional channels for double sensors and function channels
Delta - sigma, 24-bit, 2.5 / 10 / 50 / 100 measuring operations

A/D converter :
per second, adjustable 1 to 100
Sensor power supply :
200 mA

Total mains : 12 V 400 mA, rechargeable battery: 9 to 11.5 V

Selector switch board U-A10:

10 ALMEMO® sockets, suitable for ALMEMO® flat connectors
10 channels, electrically isolated, 30 additional channels with sensor power supply, 2 slots

Selector switch board U-MU:

10 inputs, electrically isolated, via 10x MU connector without sensor power supply, 30 additional channels, 1 slot

Selector switch board U-TH:

10 inputs, electrically isolated, via miniature thermocouples without sensor power supply, 30 additional channels, 1 or 2 slots
If arranged in series one dummy panel must be inserted, 4 DU

Selector switch board U-KS:

10 inputs, electrically isolated, via 2 clamp connectors without sensor power supply, 30 additional channels, 1 slot

Option KSUI:

10 inputs, A - C, with divider 100/1
Accuracy 0.1 % (22 °C), drift 0.003 % / K
10 inputs, A - B, with shunt, 2 ohms
Accuracy 0.1 % (22 °C), drift 0.005 % / K

Outputs :

2 ALMEMO® sockets for all output modules
Alarm signal transmitter, internal

Standard equipment :

Operation : 1 key (On / Off, Start / Stop)
Date and time-of-day : Real-time clock, buffered with lithium battery
Memory (option S) : 512-KB EEPROM (64,000 to 100,000 measured values)
Cannot be used at 100 measuring operations per second.

Microprocessor : M16C62P

Power supply : external 10 to 13 VDC

Mains adapter : ZA 1212-NAx, 230 VAC to 12 VDC, 2.5 A

Rechargeable battery in module AP : 8 NiMH cells, AA, 9 to 11.5 V, 1600 mAh

Current consumption

Active mode approx. 25 mA (without input and output modules)

Sleep mode approx. 0.05 mA

Selector switch boards approx. 5 mA

Housing

19-inch desktop housing, 12 DU

WxHxD 78 x 145 x 218 mm, polystyrene

19-inch desktop housing, 32 DU

WxHxD 179 x 158 x 232 mm, polystyrene shielded

19-inch desktop housing, 84 DU

WxHxD 444 x 158 x 232 mm, polystyrene shielded

19" sub-rack, 84 DU

WxHxD 483 x 132 x 273 mm

Suitable conditions

Operating temperature -10 to +50 °C (storage temperature -20 to +60 °C)

Ambient relative humidity 10 to 90 % rH (non-condensing)

Product overview

Data acquisition system ALMEMO® 5690-1M

9 inputs, maximum 40 channels, 2 outputs, cascadable interface,
real-time clock, 1 key, mains adapter 12 V / 2.5 A
in 19-inch desktop housing, 12 DU, 1 slot
in 19-inch desktop housing, 32 DU, 6 slots
in 19-inch desktop housing, 84 DU, 19 slots
in 19-inch sub-rack, 84 DU, 19 slots

Order no.

MA 56901M09TG1
MA 56901M09TG3
MA 56901M09TG8
MA 56901M09BT8

Options

S: 512-KB EEPROM integrated
R: Measuring ranges for temperature display of 8 refrigerants
KL: Linearization, multi-point calibration, calibration data management

OA 5690-S
SB 0000-R
OA 5690-KL

Extensions

Rechargeable battery module (8 NiMH cells, 1600 mAh), 1 slot
Selector switch board U-A10 with 10 inputs, electrically isolated,
for ALMEMO® flat connectors, 10 to 40 channels, 2 slots
Selector switch board U-MU with 10 inputs, electrically isolated,
Sensor connector with 10x MU connector, 10 to 40 channels, 1 slot
10x MU connector for 10 sensors, 10 to 40 channels
Selector switch board U-TH with 10 inputs, electrically isolated,
Sensor connector with thermocouple, 10 to 40 channels, 2 slots
Selector switch board U-KS with 10 inputs, electrically isolated,
Sensor connector with clamp connector, 10 to 40 channels, 1 slot
All inputs for 10 V with 100:1 divider and 20 mA with shunt
Trigger output interface (4 relays, 2 trigger inputs)
Option R02: 2 Analog output, electrically isolated -4..10V or 0..20mA

ES 5690-AP
ES 5690-UA10
ES 5690-UMU
ZA 5690-MU
ES 5690-UTH
ES 5690-UKS
ES 5690-UKSUI
ES 5690-RTA5
OA 8006-R02

Accessories

Memory connector, including SD card, minimum 128 MB, USB card reader
DC power cable, 10 to 30 VDC, 12 V / 0.25 A, electrically isolated
DC power cable, 10 to 30 VDC, 12 V / 1.25 A, electrically isolated
ALMEMO® data cable with USB interface, electr. isol., max. 230.4 kbaud
ALMEMO® data cable with V24 interface, electr. isolated, maximum 115.2 kbaud
ALMEMO® network cable, electrically isolated, maximum 115.2 kbaud
ALMEMO® data cable with Ethernet interface, electr. isol., maximum 115.2 kbaud
ALMEMO® input / output cable for triggering and limit value alarms
ALMEMO® recording cable, not electrically isolated, -1.25 to 2.00 V
ALMEMO® relay trigger analog adapter (4 relays, 2 trigger inputs)
Option R1, R2, R3: Analog output, electrically isolated, 2 V, 10 V, 20 mA

ZA 1904-SD
ZB 3090-UK
ZB 3090-UK2
ZA 1919-DKU
ZA 1909-DK5
ZA 1999-NK5
ZA 1945-DK
ZA 1006-EGK
ZA 1601-RK
ZA 8006-RTA
OA 8006-Rx

15. INDEX

Accessories	34
additional channels	16
AMR-Control	12
calibration data management	29
Check lamps	2
code switch	17
Code switch	3
code switches	23
Code switches.....	2
Combination key	23
Configuration.....	24
Connecting the transducers.....	16
Connection socket DC	2
Data buffering	15
DC socket	14
Device address	23
Device-internal channels	16
Device-internal measured value memory	26
differential channel.....	16
electrically isolated	19
Extending the measuring points	17
External DC voltage supply	14
file name	27
Functions of the ALMEMO 5690- 1M.....	8
Ground socket.....	2
Housing	33
Initial commissioning.....	13
Introduction	8
Key	2
linearization.....	29
Mains operation	14
Measured data acquisition.....	25
Measuring inputs	16
Measuring inputs	2, 3
Measuring inputs	33
Measuring operations	10
Mehrpunktkalibration	29
memory card	27
Memory connector	27
Module RTA5	3
Module U-A10	3
Module U-KS	3
Module U-MU	3
Module U-TH	3
networking	23
Offline measurement	25
Online measurement with PC	25
Operating controls	2
Operation with rechargeable battery	14
Options	34
Order no.	34
Output sockets	2
Potential separation	18
Power supply	14
Power supply	33
Process control	11
Product overview	34
read out the measured data	25
rechargeable batteries	14
rechargeable batteries	7
rechargeable battery module	8
Rechargeable battery module	34
reinitialization	15
Scope of delivery.....	7
Selector switch board U-KS	18
selector switch board U-MU	17
Selector switch board U-TH	18
selector switch boards U-A10 .	17
Sensor programming.....	9
Sensor supply	15
Sleep mode	26
Software	12
Special measuring ranges	29
Standard equipment	33
start and stop a measuring operation	25
Suitable conditions	33
Switching ON / OFF	15
Technical data	33
Transducers	16
Troubleshooting.....	30
Warranty	6
WIN-Control.....	12

YOUR CONTACT

AHLBORN Mess- und Regelungstechnik GmbH
Eichenfeldstraße 1
83607 Holzkirchen
Germany

internet : <http://www.ahlborn.com>
e-mail : amr@ahlborn.com

**Despite great care, incorrect information cannot be ruled out.
Technical changes are reserved.**